

**IMPORTANT! READ THESE INSTRUCTIONS BEFORE USE**

### Static Installation Components

If you have purchased a controller for permanent static installation in the store, you should receive the following components:



Temperature Differential Controller with power supply lead fitted with 13A plug and control output lead fitted with connector



Air temperature sensor with 10m extension lead



2m rigid crop temperature sensor with 20m extension lead

Additional or alternative components that may be included if you have ordered them:



- Automatic fan starter/thermal overload unit (for the first fan)
- Automatic starter with time delay and connecting lead (one for each fan after the first one)



Multi-switchbox selector for up to 12 crop sensors, with connecting lead to controller

**Important:** Check to ensure that each fan starter is of the correct phase and overload range for the fans being controlled

Alternatives: Crop sensors - 3m rigid or flexible cable (at specified length)  
Sensor extension leads - 30m or longer (as specified)

### Portable Board-Mounted Components

If you have purchased a portable board-mounted controller, you should receive the following components:



Board Mounted Temperature Differential Controller with power supply plug and socket set and output plugs and sockets for up to 4 fans



Air temperature sensor with 10m extension lead



2m rigid crop temperature sensor with 20m extension lead

**Important:** Check to ensure the input and output sockets are of the correct phase for the fans being controlled

Additional or alternative components that may be included if you have ordered them:

- Multi-switchbox selector for up to 12 crop sensors - built in to controller fascia
- Crop sensors - 3m rigid or flexible cable (at specified length)
- Sensor extension leads - 30m or longer (as specified)

### Introduction

The Temperature Differential Fan Controller (TDC) assists with crop temperature reduction during ventilation of stored crops and can work with a range of fan sizes in different storage applications. It operates by measuring the difference between the temperature of the crop and the air that is being used to ventilate it. If the difference is greater than the adjustable controller setting, the fan is switched on. In automatic mode a thermostat keeps the fans switched off if the air temperature falls below a pre-set level near to freezing. There is an override for manual fan operation. The TDC can operate more than one fan. The first fan is operated using a fan starter. Additional fans are operated using a starter with a timer delay.

The TDC also acts as a crop store monitoring device, with alternating crop temperature and air temperature displays on the unit.

Each TDC normally operates using just one crop sensor, but the system may be supplied with up to 12 sensors, a 12-channel selector switch and additional sensor extension cables. This enables up to 12 points in the store to be monitored simultaneously by the controller and quickly shows the hottest areas and which parts of the store require cooling the most. If the TDC is being used with Martin Lishman Pile-Dry Pedestals and Fans, this indicates where in the store to place the cooling fans. The sensor showing the hottest temperature is then linked to the controller using the channel selector on the Multi-Switchbox.

### The Equipment

#### Static Unit

The basic static unit comprises the controller, air temperature sensor with 10m extension cable and 2m rigid crop sensor with 20m extension cable. Fan starter/contacter units may also be supplied (see pictures above)

#### Portable Board-Mounted Unit

The basic board unit comprises the controller, air temperature sensor with 10m extension cable and 2m rigid crop sensor, with 20m extension cable. Up to 4 fan starter/contacter units to suit either 1 phase or 3 phase supply are fitted to the board. Each controller has an input connector complete with plug supplied, normally of 32Amp rating, and each starter has its own output connector of 16Amp rating complete with plug.

# Temperature Differential Controller

## Installation

### Important:

- This unit must be installed in compliance with the 17th IEE regulations.
- It is the purchaser's responsibility to ensure that there is an adequately rated power supply to the controller and suitable electrical connections available on site.
- It is the user's responsibility to ensure that all appropriate safety precautions are followed during the installation and use of the controller.
- A qualified electrician must install and check the controller and fan starters before use.
- The power supply to the fan(s) and to the controller must be disconnected before any connections or alterations are made.
- Appropriate safety signs should be fixed onto each fan being controlled. For example: "Warning. Automatic Control. Motor may start unexpectedly. Disconnect power supply before working on any part of the system."
- The Electricity at Work Regulations 1989 require that any electrical equipment that has the potential to cause injury is maintained in a safe condition.
- **Please Note: This unit has an IP rating of 44 and is unsuitable for installation outdoors.**

### Electrical Installation of Static Unit

- Wall mounting points are located inside each starter and the controller enclosure.
- The static TDC control unit requires a single phase 13 amp mains power supply to operate.
- Connect the power supply to each fan starter and fan as per the diagram inside the starter enclosure. An earth and neutral connection is provided inside the single phase unit; an earth connection is provided inside the three phase unit. All entry points to the unit must be made in accordance with the regulations, using appropriate glands.
- Before connecting any power supply, ensure the overload in each starter has been set to the correct rating for the fan.
- Locate the controller output lead into the left hand side socket of the first starter. Use the connector leads supplied to link the additional starters for each fan after the first one.
- After testing switch the controller to manual and ensure the fan impellers are spinning anti-clockwise when viewed from above.

The basic configuration of the installation of the LVC controller and the fan starters is as follows:

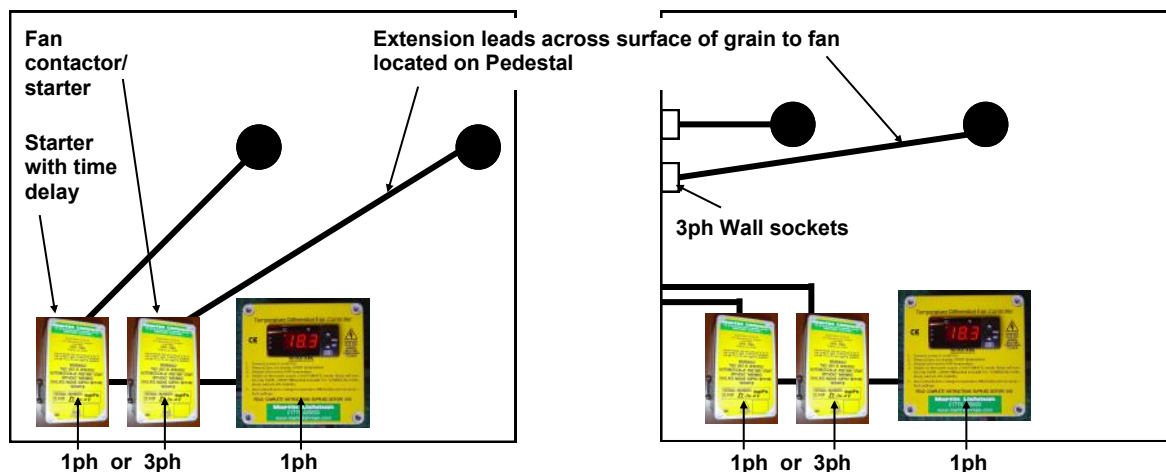
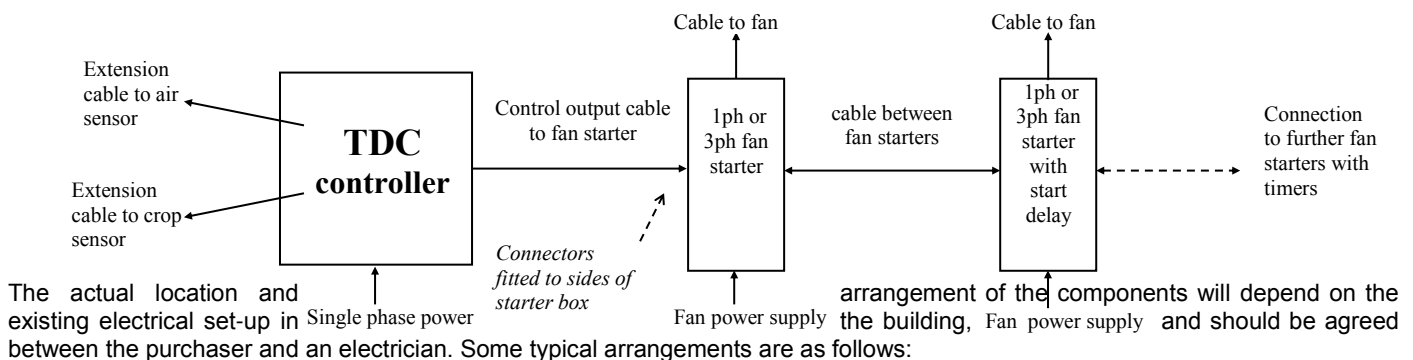

# Instructions - call 01778 426600 in case of difficulty

## Electrical Installation of Portable Board-Mounted Unit

- Position the unit where desired.
- Connect the unit to a suitable power supply using the plug supplied and suitable cable.
- Connect the fans to the plugs supplied using suitable cable.
- Plug the fans into the sockets on the board.
- Before connecting any power supply, ensure the overload in each starter is set to the correct rating for the fan.
- After testing switch the controller to manual and ensure the fan impellers are spinning anti-clockwise when viewed from above.

The typical arrangement after connection is as follows:

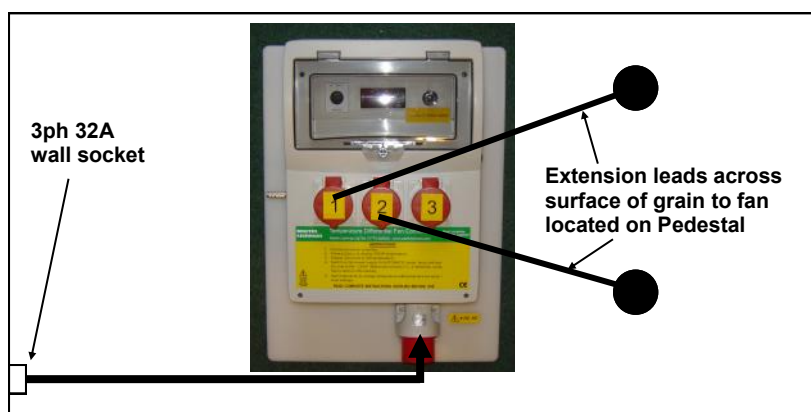

Recommended electrical and socket requirements for connection of a board-mounted controller to Pile-Dry Pedestal Fans is as follows:

Product Code	Phase	Fans	Socket
FCBM01	1	1 x F2 (1.1kW) or 1 x F3 (1.5kW)	13A or 16A (blue round pin)
FCBM02	1	2 x F2 (1.1kW)	16A (blue round pin)
		2 x F3 (1.5kW)	32A (blue round pin)
FCBM03	1	3 x F2 (1.1kW) or 3 x F3 (1.5kW)	32A (blue round pin)
FCBM04	1	4 x F2 (1.1kW)	32A (blue round pin) (not suitable for four F3 1ph fans)
FCBM301	3	1 x F2 (1.1kW) or 1 x F3 (2.2kW)	16A (red round 5 pin)
FCBM302	3	2 x F2 (1.1kW) or 2 x F3 (2.2kW)	16A (red round 5 pin)
FCBM303	3	3 x F2 (1.1kW) or 3 x F3 (2.2kW)	16A (red round 5 pin)
FCBM304	3	4 x F2 (1.1kW)	16A (red round 5 pin)
		4 x F3 (2.2kW)	32A (red round 5 pin)

Please ensure that all power supplies are correctly fused for your system

## Installation of sensors for static and portable units

- Using the 10m extension cable supplied, plug the air temperature sensor into the TDC where indicated.
- Place the air sensor where it measures the temperature of the crop ventilation air. For Pedestal systems, this is inside the building above the grain. If the air is blown in directly from outside, place it outside under the eaves.
- Using the 20m extension cable supplied, plug the crop temperature sensor into the TDC where indicated.
- Place the crop sensor in a position in the crop that is likely to receive average ventilation. This means pushing it vertically into grain, as far as it will go, approximately midway between ventilation columns or ducts, so that the grain temperature measured is representative of the bulk being ventilated.
- If a Multi-switchbox selector is being used with a static control unit, connect the short lead supplied into the 'Crop' socket on the TDC.
- If a Multi-switchbox selector is being used with a static or portable control unit, connect the additional crop sensors and extension leads supplied to the numbered sockets in the switchbox (static unit) or sides of the enclosure (portable unit).
- Place the additional crop sensors in a grid pattern in the grain, allowing approximately one sensor per 100 tons or per 10m x 10m area. Keep a written note of the location of each sensor so that consistent temperature records can be kept.

# Using the Temperature Differential Controller

- When the TDC power is switched on the display will illuminate. For normal use set the controller to *automatic*.
- The AIR temperature will be displayed constantly on the controller display. To display the CROP temperature measured by the crop sensor, hold the ▲ key for no more than about 2 seconds, then release. The CROP temperature will display for approximately 5 seconds. If the ▲ key is not released and is kept pressed for up to 5 seconds this will cause the display to show the frost thermostat setting (pre-set at 3.0) and then revert to the air temperature reading.
- The *temperature differential* is pre-set at 5°C (as recommended by HGCA, but see below to change). When the crop temperature is more than 5°C above the air temperature, the fan will switch on. When the crop is at or less than 5°C above the air temperature, the fan will switch off. If air temperature exceeds crop temperature, the fans will not run. The light at *Number 1* in the controller display illuminates when fans are running.
- As the air temperature cools, the crop temperature will also be cooled whilst maintaining a constant differential.
- If the TDC is set to *manual*, the fan will run when its power is on. If the TDC is set to *automatic*, and either sensor is not connected or is faulty, E1 or E2 will be displayed and the fan will stay switched off. The fan can still be operated by turning to *manual*.
- A variable *fan run time* facility prevents the fan switching on and off too frequently when crop temperature becomes close to the set differential. This time period is set to 10 minutes. This means the fan will not run for 10 minutes, even after suitable conditions occur, irrespective of the temperature differential.
- The *frost thermostat* is pre-set at 3°C (see below to change). When the air temperature reaches this level the fans will not operate. When the frost thermostat is operative, the light at *Number 2* in the controller display will be off and the air temperature will display 3°C or less.
- The *frost thermostat* can be adjusted by entering programme set up. This is done by pressing both ▲ and ▼ buttons simultaneously and releasing after 1 – 2 seconds. Mode 01 should be displayed on screen. Then using the ▲ button, scroll to Mode 20 then press both ▲ and ▼ buttons as before. The display will initially show as 3. The frost setting can now be altered using ▲ or ▼ buttons. Then press both ▲ and ▼ buttons to exit mode. To exit programme set up scroll down to EP and press both ▲ and ▼ to exit. The display will show the air temperature once more.
- The *temperature differential* can be re-set as follows:  
Access the program of the controller as above, but scroll up to Mode 11. When on 11 press both ▲ and ▼ to access the differential settings. This works in reverse. The display will initially show as -5, so if a differential of 3°C is required then you must scroll to -3. When you have input your desired differential press both ▼ and ▲ to exit mode. To exit programme set up scroll down to EP and press both ▲ and ▼ to exit. The display will show the air temperature once more.

**Information about the only adjustments that might be required is as given above. For more detail on programming the TDC, please see the separate sheet of instructions.**

## Warranty

The TDC (the unit) is guaranteed for 12 months from the date of purchase against any defect or malfunction caused by faulty parts or workmanship. To claim under warranty, the complete unit or part should be returned, at the claimant's expense, to Martin Lishman Ltd with a written explanation of the problem. Should there prove to be a defect or malfunction caused by faulty parts or workmanship, it will be repaired or replaced and returned to the claimant without charge. If a warranty claim is rejected, the cost of replacement or repair will be notified to the claimant before any work is carried out. Any warranty claim will automatically be invalidated if the unit has been modified or internally tampered with in any way. The manufacturers will not cover under warranty damage or faults occurring to the unit which have been caused by inappropriate use or by use not in accordance with the installation and operating instructions for the unit or the fan being used with the unit.

It is the responsibility of the user to ensure that all electrical equipment has been installed in accordance with the relevant regulations, that all appropriate safety checks have been carried out before use and that regular on-going maintenance and safety checks are undertaken.

Under no circumstances will Martin Lishman Ltd re-imburse any costs associated with a warranty claim if these costs have been incurred without agreement in advance.

Under the terms of warranty for the unit under no circumstances will liability exceed the cost of replacement or repair. The manufacturers and Martin Lishman Ltd will not be liable for any consequential or indirect loss suffered by purchasers or users of the unit, whether this loss arises from correct or incorrect use, defect or malfunction caused by faulty parts or workmanship or in any other way. Non-exhaustive illustrations of consequential or indirect loss are loss of profits, loss of contracts and damage to property.